

OPL-DAC-100G Series

100Gbps QSFP28 Passive High Speed Cable



Description

OPL-DAC-100G Series, the 100G QSFP28 Direct Connect Cable (DAC) is a 4-channel parallel passive copper product for storage, data centers and high-performance computing connections. Each channel is capable of transmitting data at 25 Gbps, enabling a 100 Gbps total data rate of 5 meters.

Features

- Enhanced EMI / EMC performance
- 25Gbps data transfer rate per channel, up to 100Gbps
- Compliant with the IEEE 802.3bj standard and Infiniband EDR specifications
- Meets QSFP + MSA and SFF-8661 / SFF-8665 standards
- Support serial ID function through EEPROM
- 30AWG to 26AWG cable available
- RoHS and halogen-free options

Applications

- Switch / router / HBA / SAN, NIC card
- 40G \ 100G Ethernet
- Storage, switch, data center, network center
- Infiniband, QDR / EDR

Outline Drawing

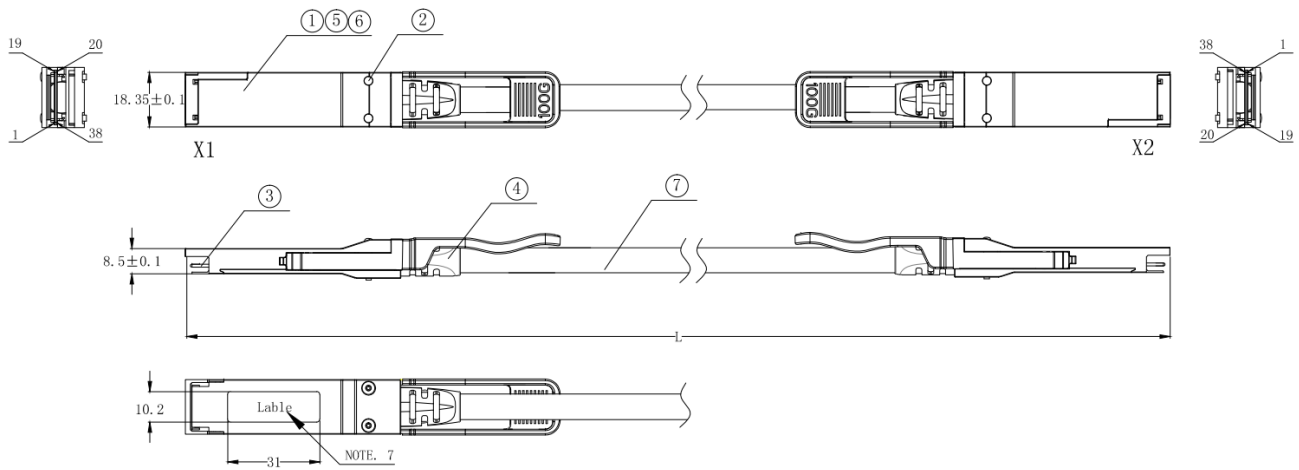

Wiring Diagram

X1	X2	REMARKS	X1	X2	REMARKS
18(RX1-)	37(TX1-)	pair	37(TX1-)	18(RX1-)	pair
17(RX1+)	36(TX1+)		36(TX1+)	17(RX1+)	
15(RX3-)	34(TX3-)	pair	34(TX3-)	15(RX3-)	pair
14(RX3+)	33(TX3+)		33(TX3+)	14(RX3+)	
6 (TX4+)	25(RX4+)	pair	25(RX4+)	6 (TX4+)	pair
5 (TX4-)	24(RX4-)		24(RX4-)	5 (TX4-)	
3 (TX2+)	22(RX2+)	pair	22(RX2+)	3 (TX2+)	pair
2 (TX2-)	21(RX2-)		21(RX2-)	2 (TX2-)	
1, 4, 7, 13, 16, 19, 20, 23, 26, 32, 35, 38	1, 4, 7, 13, 16, 19, 20, 23, 26, 32, 35, 38	GND	8, 9, 10, 11, 12, 27, 28, 29, 30, 31	8, 9, 10, 11, 12, 27, 28, 29, 30, 31	EEPROM point at both ends

Electrical Performance

Signal Integrity

(ITEM)		(REQUIREMENT)	(TEST CONDITION)
(Differen tial	Cable Impedance	105+5/-10Ω	Rise time of 25ps

Impedance)	Paddle Card Impedance	100±10Ω					(20 % - 80 %).	
	Cable Termination Impedance	100±15Ω						
[Differential (Input/Output)Return loss S _{DD11} /S _{DD22}]		$\text{Return_loss}(f) \geq \left\{ \begin{array}{l} 16.5-2\sqrt{f} \\ 0.05 \leq f < 4.1 \end{array} \right\}$					10MHz≤f≤19GHz	
Where		f is the frequency in GHz						
Return loss(f) is the return loss at frequency f								
[Differential to common-mode (Input/Output)Return loss S _{CD11} /S _{CD22}]		$\text{Return_loss}(f) \geq \left\{ \begin{array}{l} 22-(20/25.78)f \\ 0.01 \leq f < 12.89 \end{array} \right\}$					10MHz≤f≤19GHz	
Where		f is the frequency in GHz						
Return_loss(f) is the Differential to common-mode return loss at frequency f								
[Common-mode to Common-mode (Input/Output)Return loss S _{CC11} /S _{CC22}]		$\text{Return_loss}(f) \geq 2\text{dB} \quad 0.2 \leq f \leq 19$					10MHz≤f≤19GHz	
Where		f is the frequency in GHz						
Return_loss(f) is the common-mode to common-mode return loss at frequency f								
[Differential Insertion Loss (S _{DD21} Max.)]		(Differential Insertion Loss Max. For TP _a to TP _b Excluding Test fixture)					10MHz≤f≤19GHz	
F / AWG		1.25GHz	2.5GHz	5.0GHz	7.0GHz	10Ghz		12.89Ghz
30(1m) Max.		4.5dB	5.4dB	6.3dB	7.5dB	8.5dB		10.5dB
30/28(3m)Max.		7.5dB	9.5dB	12.2dB	14.8dB	18.0dB	21.5dB	

	26(3m) Max.	5.7dB	7.2dB	9.9 dB	11.9dB	14.1dB	16.5dB	
	26/25(5 m)Max.	7.8dB	10.0dB	13.5dB	16.0dB	19.0dB	22.0dB	
[Insertion Loss Deviation]	$-0.176*f - 0.7 \leq \text{ILD} \leq 0.176* f + 0.7$							50MHz \leq f \leq 19GHz
Differential to common-mode Conversion Loss-Differential Insertion Loss(S_{CD21} - S_{DD21})	$\text{Conversion_loss}(f) - \text{IL}(f) \geq \begin{cases} 10 & 0.01 \leq f < 12.89 \\ 27-(29/22)f & 12.89 \leq f < \end{cases}$ <p>Where f is the frequency in GHz Conversion_loss(f) is the cable assembly differential to common-mode conversion loss IL(f) is the cable assembly insertion loss</p>							10MHz \leq f \leq 19GHz
[MDNEXT(multiple disturber near-end crosstalk)]	$\geq 35\text{dB} @ 12.89\text{GHz}$							10MHz \leq f \leq 19GHz
[Intra Skew]	15ps/m,							10MHz \leq f \leq 19GHz

Other Electrical Performance

(ITEM)	(REQUIREMENT)	(TEST CONDITON)
[Low Level Contact Resistance]	70milliohms Max. From initial.	EIA-364-23:Apply a maximum voltage of 20mV And a current of 100 mA.
Insulation Resistance	10Mohm(Min.)	EIA364-21:AC 300V 1minute
[Dielectric Withstanding Voltage]	NO disruptive discharge.	EIA-364-20:Apply a voltage of 300 VDC for 1minute between adjacent terminals And between adjacent terminals and ground.

Environment Performance

(ITEM)	(REQUIREMENT)	(TEST CONDITON)
[Operating Temp. Range]	-20°C to +75°C	Cable operating temperature range.
[Storage Temp. Range (in packed condition)]	-40°C to +80°C	Cable storage temperature range in packed condition.
[Thermal Cycling Non-Powered]	No evidence of physical damage	EIA-364-32D, Method A, -25 to 90C, 100 cycles, 15 min. dwells
[Salt Spraying]	48 hours salt spraying after shell corrosive area less than 5%.	EIA-364-26
Mixed Flowing Gas	Pass electrical tests per 3.1 after stressing. (For connector only)	EIA-364-35 Class II, 14 days.
Temp. Life	No evidence of physical damage	EIA-364-17C w/ RH, Damp heat 90°C at 85% RH for 500 hours then return to ambient
Cable Cold Bend	4H, No evidence of physical damage	Condition: -20°C±2°C, mandrel diameter is 6 times the cable diameter.

Mechanical and Physical Characteristics

(ITEM)	(REQUIREMENT)	(TEST CONDITON)
Vibration	Pass electrical tests per 3.1 after stressing.	Clamp & vibrate per EIA-364-28E, TC-VII, test condition letter – D, 15 minutes in X, Y & Z axis.
Twist	No evidence of physical damage	Twist cable 180° (±90° from nominal position) for 100 cycles at 30 cycles per minute with a 0.5kg load applied to the cable jacket. Clamp position: 300mm
Cable Flex	No evidence of physical damage	Flex cable 180° for 20 cycles (±90° from nominal position) at 12 cycles per minute with a 1.0kg load applied to the cable jacket. Flex in the boot area 90° in each direction from

		vertical. Per EIA-364-41C
Cable Plug Retention in Cage	90N Min. No evidence of physical damage	Force to be applied axially with no damage to cage. Per SFF 8661 Rev 2.1 Pull on cable jacket approximately 1 ft behind cable plug. No functional damage to cable plug below 90N. Per SFF-8432 Rev 5.0
Cable Retention in Plug	90N Min. No evidence of physical damage	Cable plug is fixtured with the bulk cable hanging vertically. A 90N axial load is applied (gradually) to the cable jacket and held for 1 minute. Per EIA-364-38B
Mechanical Shock	Pass electrical tests Per 3.1 after stressing.	Clamp and shock per EIA-364-27B, TC-G,3 times in 6 directions, 100g, 6ms.
Cable Plug Insertion	40N Max.(QSFP28)	Per SFF8661 Rev 2.1
Cable plug Extraction	30N Max. (QSFP28)	Place axial load on de-latch to de-latch plug.Per SFF8661 Rev 2.1
Durability	50 cycles,No evidence of physical damage	EIA-364-09, perform plug &unplug cycles:Plug and receptacle mate rate: 250times/hour. 50times for QSFP28/SFP28 module (CONNECTOR TO PCB)